

4

3

2

1

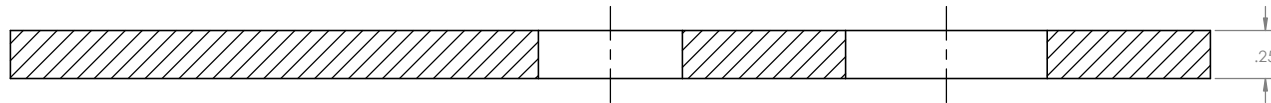
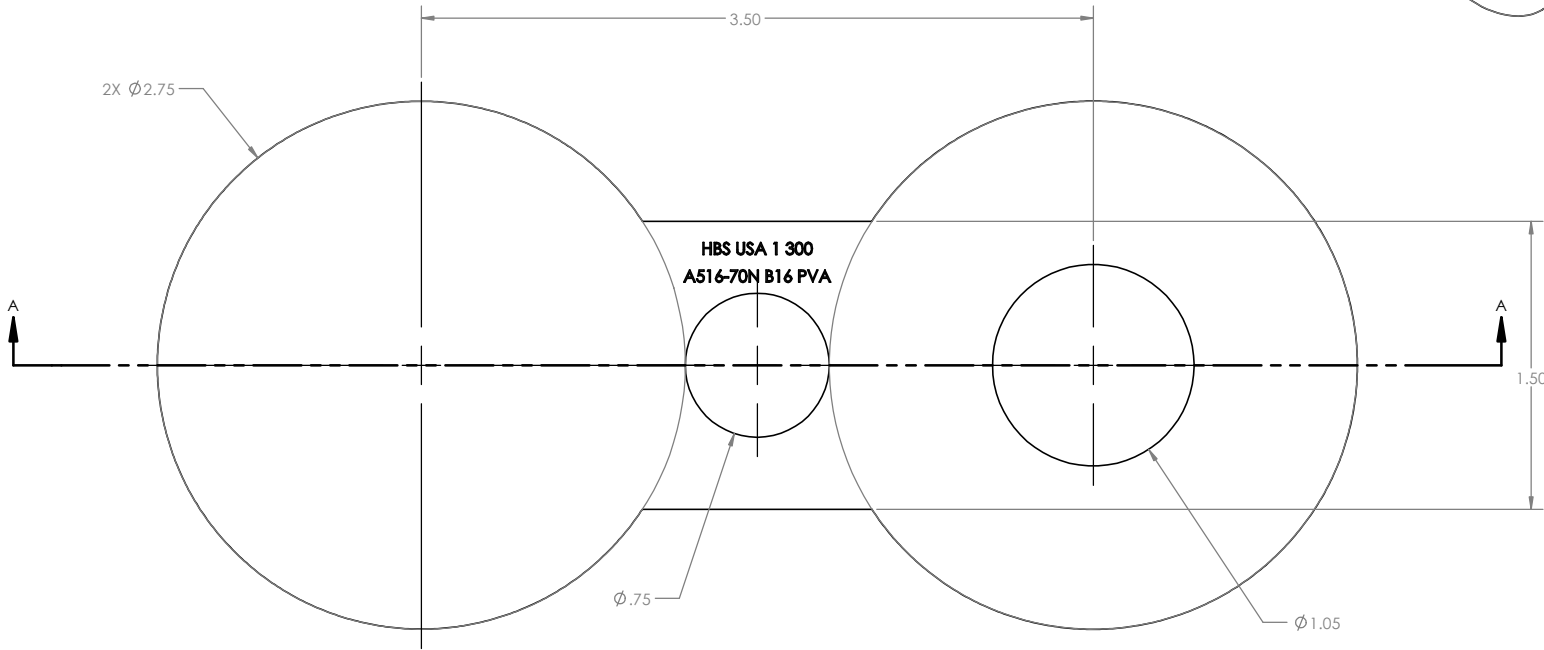
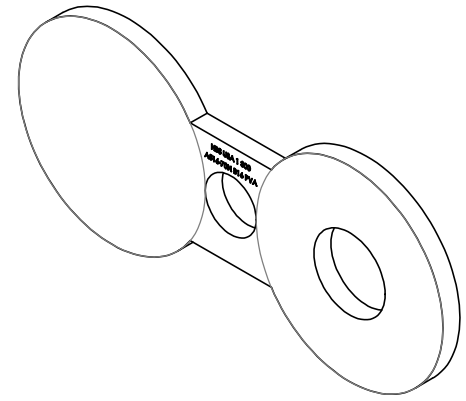

SECTION A-A

DO NOT SCALE PRINT		UNLESS OTHERWISE SPECIFIED: OUTSIDE DIAMETER: (+/-0.12) INSIDE DIAMETER: (+/-0.12) THICKNESS TOLERANCES (-ZERO +0.12) ALL UNITS IN INCHES OR POUNDS		HYDROBLIND -ISOLUTIONS	
 <small>THIRD ANGLE PROJECTION</small>		SHEET 1 OF 1			SURFACE FINISH: MACHINE OR MILL
MATERIAL: CUSTOMER REQUESTED		DATE: 06/24/2020		DRAWING TITLE: 1 CL 300 FIGURE 8 BLIND	
SCALE: 2:1	SIZE: C	DIMENSIONS & TOLERANCES TO BE IN ACCORDANCE WITH ASME B16.48	WEIGHT: 1 lb	REV: 00	
		DRAWING NUMBER: 3SBH			

4

3

2

1

D

D

C

C

B

B

A

A